

# OPUS line

## Technical manual



# OPUS 80

## StraightBolt

EM35-20 Technical Manual

### CHARACTERISTICS

The StraightBolt lock can be mounted in all four mounting directions. The mounting dimensions are standard. The lock is delivered with either metric (M6) mounting screws or US 1/4 – 20 screws. The Electronics feature a 6-digit Main code that can be changed by the user. With the main code, a secondary code can be activated and deleted. If a valid code has been entered, the lock electronics remove the blocking for 3 seconds and the bolt can be moved into the housing by turning an internal driving cam with a turnable entry unit or a knob. After moving the bolt into LOCKED position, the StraightBolt automatically secures.

### ENTRY UNITS

The StraightBolt is compatible with the following turnable OPUS Entry units:

|  |  |
|--|--|
|  | <p>Bravo BR20 Series</p> <p>SECURITY</p> |
|  | <p>Delta DE20 Series</p>                 |

(Separate technical descriptions for Entry units available)



## BOLTWORK REQUIREMENTS and MOUNTING INSTRUCTION

Only use supplied screws to mount the lock. Tighten the screws securely so the lock body is attached firmly to the mounting surface.

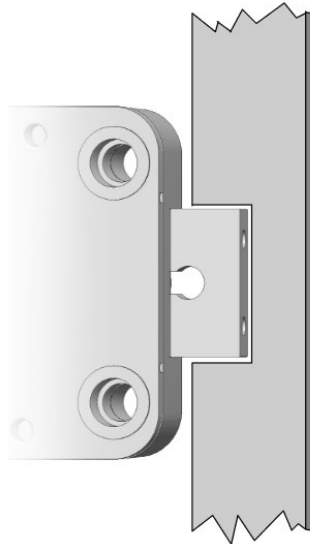

In the LOCKED position, there should be approximately 1 mm clearance between the lock bolt and the cavity in the blocking bar of the boltwork. The lock bolt must move freely into the cavity..

**DO NOT OVER TORQUE MOUNTING SCREWS.**

Mount the entry unit following the manufacturer's instruction. The grooved shaft must extend between 10 and 15 mm off the mounting surface. Make sure the cable is in the groove.

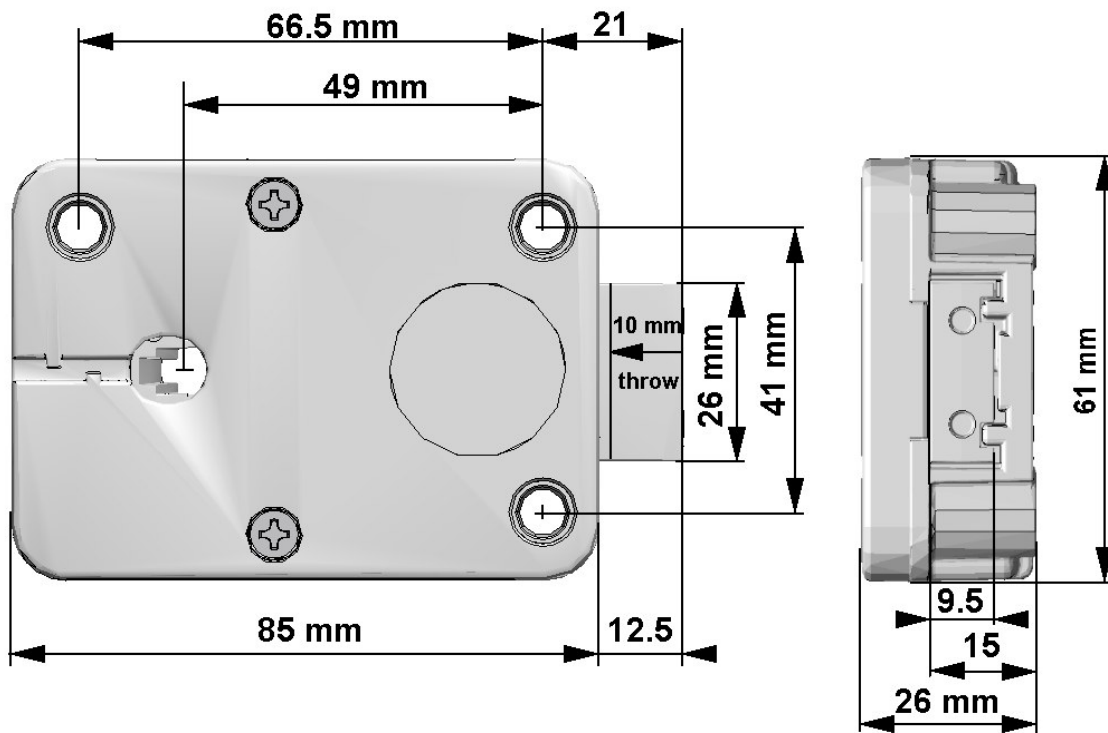

Insert the cable connector into the square hole in the bottom of the lock and guide it through the hole in the lock cover. Holding the cable straight place the lock with the square cavity on the grooved shaft and then screw it to the mounting surface. Insert the connector of the entry unit in the outer position.

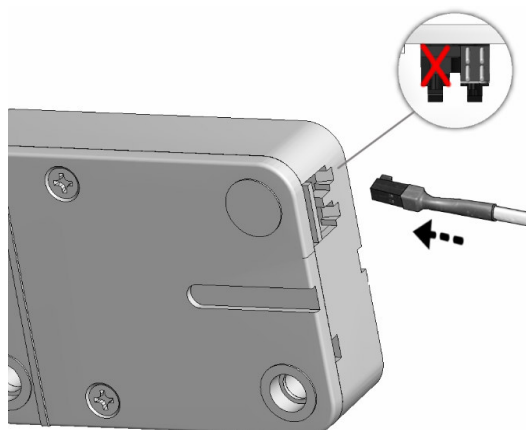

To remove the connector, lift it up and carefully pull it out.

To tie the cable, push it into the square groove in the lock cover. In the entry unit or battery box, connect a 9V-ALKALINE-battery from a brand name manufacturer, e.g. DURACELL. **A series of signals during opening indicates that the battery is weak and must be replaced.**

In the entry unit or battery box, connect a 9V-ALKALINE-battery from a brand name manufacturer, e.g. DURACELL. **A series of signals during opening indicates that the battery is weak and must be replaced.** Tie cables away from moving parts.

**IMPORTANT: Perform the functional tests several times before locking the safe door.**

#### FUNCTIONAL TEST (with door open)

##### A. Test Electronics

Like other Opus locks, this unit includes a unique feature to test the electronics: "Function 5"

| STEP | TASK   | REMARK  |
|------|--|---|
| 1    | Press and hold [5] until a double signal sounds and the light stays ON.                      |   |
| 2    | Enter the all keys in exactly this sequence:<br>[1]-[2]-[3]-[4]-[5]-[6]-[7]-[8]-<br>[9]- [0] | Push buttons slowly so you recognize the signalling of the lock. A double signal indicates that the keypad and the lock communicate properly.<br><br>A long signal indicates that the electronics may be damaged. |

## B. Mechanical Test

- Enter code (1,2,3,4,5,6). The lock emits a double signal for the correct code.
- Turn Entry unit clockwise until stop. Lock bolt must move freely. Boltwork/door can be opened.
- Move boltwork into Locked Position. Lock bolt must fully extend and secure.

DATA SHEET

|                         |  |
|-------------------------|--|
| <b>Mechanics</b>        |  |
| Opening                 | Manual   |
| Locking                 | Manual   |
| Blocking element        | Motor  |
| Mounting dimensions     | standard   |
| <b>Electronics</b>      |  |
| Power supply            | 9V ALKALINE battery                              |
| <b>Software (*)</b>     |  |
| Codes                   | 2 (6 digits)                                     |
| Primary code            | 1  |
| Secondary code          | 1  |
| Battery low signal      | yes  |
| Manipulation protection | 5 minute lockout after 4 consecutive wrong codes |
| <b>Certifications</b>   |  |
| VdS                     | Class 2  |
| EN 1300                 | Class B  |
| UL                      | Type 1   |

(\*) Other software options available

